

# Qubo

DV703



**LINEA BANCONI**  
COUNTERS LINE  
SERIE MOSTRADORES  
LIGNES COMPTOIR  
REZEPTIONPROGRAMME  
LINHA BALCÃO

DV702  
LED

DV701  
ABAKO

DV703  
QUBO

## Simboli - symbols - símbolos - symboles - symbole - símbolos



### **articolo non in pronta consegna. Per la disponibilità contattare l'ufficio commerciale**

item not in prompt delivery. Please contact the commercial department for checking availability  
producto no disponible en stock. Para la disponibilidad contactar con el departamento comercial  
article non disponible en stock. Merci de contacter le service commercial pour vérifier la disponibilité  
Dieses Produkt ist nicht sofort lieferbar. Setzen Sie sich mit unserem Handelsbüro in Verbindung für die Warenverfügbarkeit  
produtos não pronta entrega. Acerca da disponibilidade, contactar o sector comercial

---



### **non utilizzabile come terminale**

it cannot be used as a terminal side  
no se puede utilizar como terminal  
non compatible comme joue d'extrémité  
nicht als Abschluss-Seitenwand verwendet werden  
não utilizar como terminal

---



### **fino ad esaurimento**

until exhaustion  
hasta que se agoten  
soumises à disponibilité  
bis Erschöpfung  
até à exaustão

---

# DV703 Qubo

Finiture - finishes - acabados - finitions - farben - acabamentos

## V01 Piani di lavoro in melaminico sp. 25 mm

Melamine worktops 25 mm thick  
Sobres de trabajo en melamina 25 mm de grosor  
Plans de travail en mélaminé ép. 25 mm  
Tischplatten aus Melamin St. 25 mm  
Planos de trabalho em melaminico esp. 25 mm



<b>WN</b>	<b>GQ</b>	<b>RC</b>
Bianco	Grigio chiaro	Rovere chiaro
White	Light grey	Light oak
Blanco	Gris claro	Roble claro
Blanc	Gris clair	Chêne clair
Weiss	Hellgrau	Eiche hell
Branco	Cinza claro	Carvalho claro

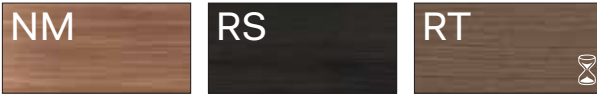

<b>NM</b>	<b>RS</b>	<b>RT</b>
Noce "Maroncelli"	Rovere scuro	Rovere tabacco
Walnut "Maroncelli"	Dark oak	Tobacco oak
Nogal "Maroncelli"	Roble oscuro	Roble tabaco
Noyer "Maroncelli"	Chêne foncé	Chêne tabac
Nussbaum "Maroncelli"	Eiche dunkel	Eiche tabak
Nogueira "Maroncelli"	Carvalho escuro	Carvalho tabaco

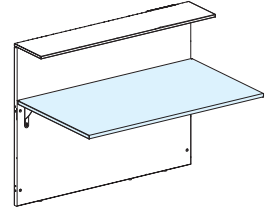

## V03 Pannelli verticali in melaminico sp. 25 mm

Vertical panels in melamine 25 mm thick  
Paneles verticales en melamina de 25 mm de grosor  
Panneaux verticaux en mélaminé ép. 25 mm  
Senkrechte Paneele aus Melamin St. 25 mm  
Painéis verticais em melaminico espessura 25 mm

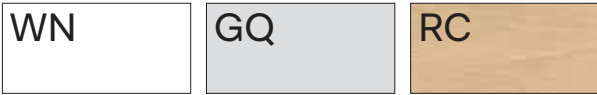

<b>WN</b>	<b>GQ</b>	<b>RC</b>
Bianco	Grigio chiaro	Rovere chiaro
White	Light grey	Light oak
Blanco	Gris claro	Roble claro
Blanc	Gris clair	Chêne clair
Weiss	Hellgrau	Eiche hell
Branco	Cinza claro	Carvalho claro

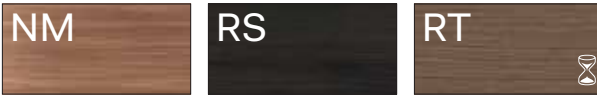

<b>NM</b>	<b>RS</b>	<b>RT</b>
Noce "Maroncelli"	Rovere scuro	Rovere tabacco
Walnut "Maroncelli"	Dark oak	Tobacco oak
Nogal "Maroncelli"	Roble oscuro	Roble tabaco
Noyer "Maroncelli"	Chêne foncé	Chêne tabac
Nussbaum "Maroncelli"	Eiche dunkel	Eiche tabak
Nogueira "Maroncelli"	Carvalho escuro	Carvalho tabaco

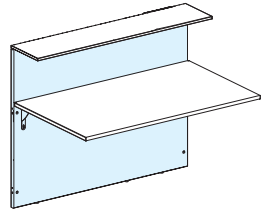

## V01 Top in laminato sp. 18 mm

Laminate tops 18 mm  
Encimeras en laminado 18 mm de grosor  
Top en laminé ép. 18 mm  
Abdeckplatte aus Laminat St. 18 mm  
Tampo superior em laminado de espessura de 18 mm



**WL**

Bianco lucido

Polished white  
Blanco brillo  
Blanc luisant  
Weiß hochglanz  
Branco brilhante

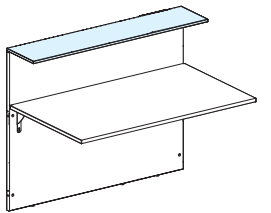

# DV703 Qubo

## Finiture - finishes - acabados - finitions - farben - acabamentos

**V01 Top in melaminico sp. 18 mm**  
 Melamine tops 18 mm thick  
 Encimeras en melamina 18 mm de grosor  
 Top en mélaminé ép. 18 mm  
 Abdeckplatte in Melamin St. 18 mm  
 Tampo superior em melaminico espessura 18 mm



<b>GQ</b> Grigio chiaro Light grey Gris claro Gris clair Hellgrau Cinza claro	<b>RC</b> Rovere chiaro Light oak Roble claro Chêne clair Eiche hell Carvalho claro	<b>NM</b> Noce "Maroncelli" Walnut "Maroncelli" Nogal "Maroncelli" Noyer "Maroncelli" Nussbaum "Maroncelli" Nogueira "Maroncelli"	<b>RS</b> Rovere scuro Dark oak Roble oscuro Chêne foncé Eiche dunkel Carvalho escuro	<b>RT</b> Rovere tabacco Tobacco oak Roble tabaco Chêne tabac Eiche tabak Carvalho tabaco
---	---	---	---	---

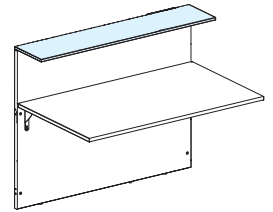

**V04 M1 Top accettazione**  
 Decorative top  
 Encimera decorativa  
 Top décoratif  
 Empfangstheke Aufsatzplatte  
 Tampo atendimento

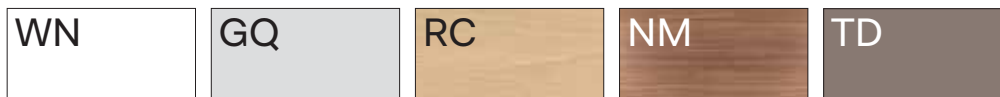

<b>WN</b> Bianco White Blanco Blanc Weiss Branco	<b>GQ</b> Grigio chiaro Light grey Gris claro Gris clair Hellgrau Cinza claro	<b>RC</b> Rovere chiaro Light oak Roble claro Chêne clair Eiche hell Carvalho claro	<b>NM</b> Noce "Maroncelli" Walnut "Maroncelli" Nogal "Maroncelli" Noyer "Maroncelli" Nussbaum "Maroncelli" Nogueira "Maroncelli"	<b>TD</b> Terra d'ombra Umber Tierra sombra Terre d'ombre Umbr Terra sombra
--	---	---	---	---

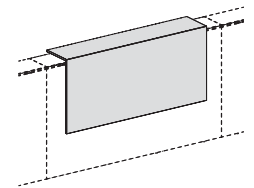

<b>RS</b> Rovere scuro Dark oak Roble oscuro Chêne foncé Eiche dunkel Carvalho escuro	<b>RT</b> Rovere tabacco Tobacco oak Roble tabaco Chêne tabac Eiche tabak Carvalho tabaco	<b>V04 M2</b>	<b>NO</b> Nero opaco Matt black Negro mate Noir mat Schwarz matt Preto opaco
---	---	---------------	--

**V02 Colonna / Gamba intermedia**  
 Column / Middle leg  
 Columna / Pata intermedia  
 Colonne / Piètement intermédiaire  
 Säule / gerade Zwischentischbein  
 Coluna / Perna intermediária



<b>W</b> Bianco White Blanco Blanc Weiß Branco	<b>H</b> Alluminio Aluminium Aluminio Aluminium Aluminium Aluminio
--	--

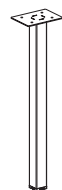

**Zoccoli**  
 Base frame  
 Zocalos  
 Socles  
 Sockel  
 Rodapés

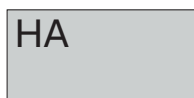

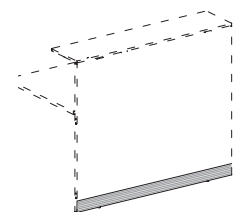

**HA**  
 Alluminio "anodizzato"  
 "anodized" aluminium  
 aluminio "anodizado"  
 aluminium "anodisé"  
 "eloxiert" Aluminium  
 alumínio "anodizado"



# DV703 Qubo

M1	V01 top top	GQ	RC	NM	RS	RT
	V01 piani worktops	GQ	RC	NM	RS	RT

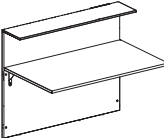
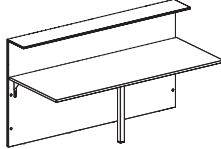
L	V01 top top	WL
	V01 piani worktops	WN

MODULI BANCONE RECEPTION UNITS	L. W.	P. D.	H. H.	CODICE CODE	V01		Kg. lb	m <sup>3</sup> ft <sup>3</sup>	n. no.	
					M1	L				
 <p><b>modulo bancone dritto</b> straight reception unit módulo mostrador recto module comptoir droit gerade Rezeption módulo balcão recto</p>	80 31 1/2"	84 33 1/8"	112,5 44 3/8"	<b>703.MB.01.08</b>	<b>328</b>	<b>378</b>	33,40 73,64	0,085 3,00	4 4	
	140 55 1/8"	84 33 1/8"	112,5 44 3/8"	<b>703.MB.01.14</b>	<b>442</b>	<b>513</b>	57,80 127,44	0,142 5,01	4 4	
	160 63"	84 33 1/8"	112,5 44 3/8"	<b>703.MB.01.16</b>	<b>476</b>	<b>549</b>	64,20 141,56	0,160 5,65	4 4	
 <p><b>modulo bancone dritto</b> straight reception unitm módulo mostrador recto module comptoir droit gerade Rezeption módulo balcão recto</p>	Non disponibile - RS / NM Not available - RS / NM	200 78 3/4"	84 33 1/8"	112,5 84"	<b>703.MB.01.20</b>	<b>738</b>	<b>781</b>	82,30 181,47	0,204 7,20	6 6
						V04 colonna column	H	W		
 <p><b>modulo bancone raccordo 90° 2 vie</b> 90° 2-ways corner reception unit módulo mostrador angulo 90° elemento de unión 2 vías module comptoir raccord 90° 2 voies Empfangstischmodulecke 90° 2-weg módulo balcão interligação 90° 2 vias</p>	!	84 33 1/8"	84 33 1/8"	112,5 44 3/8"	<b>703.MB.03.08</b>	<b>567</b>	<b>703</b>	57,20 126,12	0,120 4,24	4 4

# DV703 Qubo

M1	V01 top top	GQ	RC	NM	RS	RT
	V01 piani worktops	GQ	RC	NM	RS	RT

L	V01 top top	WL
	V01 piani worktops	WN

V81 Verso Hand	Sx	Dx
----------------	----	----

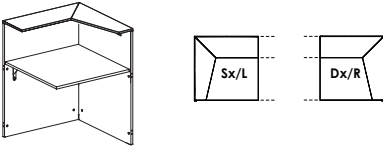

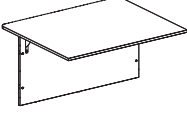

MODULI BANCONE RECEPTION UNITS	L. W.	P. D.	H. H.	CODICE CODE	V01 / V81		Kg. lb	m <sup>3</sup> ft <sup>3</sup>	n. no.	
					M1	L				
 <p><b>modulo bancone terminale 90° sinistro o destro</b></p> <p>90° terminal corner reception unit left or right</p> <p>módulo mostrador angulo 90° I vía izquierdo o derecho</p> <p>module comptoir terminal 90° gauche ou droite</p> <p>Endempfangstischmodul 90°, links oder rechts</p> <p>módulo balcão terminal esquerdo o direito</p>	Sx./L. Dx./R.	84 33 1/8"	85 33 1/2"	112,5 44 3/8"	<b>703.MB.04.08</b>	<b>585</b>	<b>714</b>	58,50 128,99	0,122 4,31	5 5

M1	V01 piani worktops	WN	GQ	RC	NM	RS	RT
----	--------------------	----	----	----	----	----	----

MODULI BANCONE RECEPTION UNITS	L. W.	P. D.	H. H.	CODICE CODE	V01	Kg. lb	m <sup>3</sup> ft <sup>3</sup>	n. no.	
					M1				
 <p><b>modulo bancone dritto con piano conversazione</b></p> <p>straight reception unit with conversation top</p> <p>módulo mostrador recto con tablero de conferencia</p> <p>module comptoir droit avec plateau accueil</p> <p>gerade Rezeption mit Gesprächsplatte</p> <p>módulo balcão com mesa de atendimento</p>	🔊	140 55 1/8"	115 45 3/8"	74 29 1/4"	<b>703.MB.02.14</b>	<b>374</b>	51,30 113,11	0,111 3,92	3 3

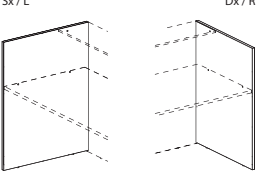
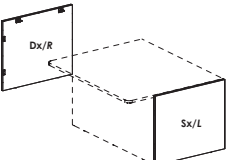
M1	V01 fianchi sides	WN	GQ	RC	NM	RS	RT
----	-------------------	----	----	----	----	----	----

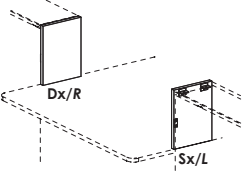
V81 Verso Hand	Sx	Dx
----------------	----	----

FIANCHI BANCONE SIDES UNITS	L. W.	P. D.	H. H.	CODICE CODE	V01 / V81	Kg. lb	m <sup>3</sup> ft <sup>3</sup>	n. no.	
					M1				
 <p><b>fianco terminale sinistro o destro</b></p> <p>left or right terminal side</p> <p>lateral terminal izquierdo o derecho</p> <p>côté d'extrémité gauche ou droit</p> <p>Abschluss-Seitenwand, links oder rechts</p> <p>lateral terminal esquerdo o derecho</p>	Sx./L. Dx./R.	84 33 1/8"	2,5 1"	112,5 44 3/8"	<b>703.FC.01.08</b>	<b>161</b>	18,40 40,57	0,044 1,55	2 2
 <p><b>fianco terminale per piano conversazione, sinistro o destro</b></p> <p>left or right terminal side for conversation top</p> <p>cubierta lateral para tablero de conferencia, izquierda o derecha</p> <p>côté d'extrémité accueil, gauche ou droite</p> <p>Abschluss-Seitenwand für Gesprächsplatte, links oder rechts</p> <p>lateral terminal esquerda o direito, com mesa de atendimento</p>	 Sx./L. Dx./R.	84 33 1/8"	2,5 1"	74 29 1/4"	<b>703.FC.03.08</b>	<b>122</b>	13,70 30,20	0,030 1,06	2 2
 <p><b>copertura superiore conversazione, sinistro o destro</b></p> <p>left or right superior cover for conversation unit</p> <p>cubierta superior módulo conferencia, izquierda o derecha</p> <p>couverture haute accueil, gauche ou droite</p> <p>Spitze Abdeckung für Gesprächsplatte, links oder rechts</p> <p>cobertura superior atendimento, esquerda o direita</p>	 Sx./L. Dx./R.	28 11 1/8"	2,5 1"	39 15 3/8"	<b>703.CT.A1.02</b>	<b>76</b>	4,00 8,82	0,007 0,24	2 2

Zoccoli Metal frames	HA
-------------------------	----

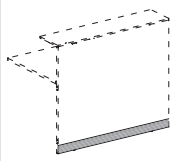
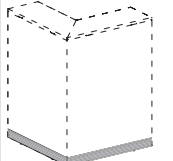

COMPONENTI PER BANCONE COMPONENTS FOR RECEPTION	L. W.	P. D.	H. H.	CODICE CODE	PREZZO PRICE	Kg. lb	m <sup>3</sup> ft <sup>3</sup>	n. no.
 <p><b>zoccolo metallico per modulo bancone (optional)</b></p> <p>base metal frame for straight reception unit (optional)</p> <p>zócalo metálico para módulo mostrador recto (opcional)</p> <p>socle métallique pour module comptoir droit (option)</p> <p>Metallsockel für gerade Rezeption (Optional)</p> <p>rodapé metálico para módulo balcão (opcional)</p>	80 31 1/2"	2,5 1"	8 3 1/4"	<b>703.ZB.01.08</b>	<b>29</b>	1,00 2,20	0,002 0,07	1 1
	140 55 1/8"	2,5 1"	8 3 1/4"	<b>703.ZB.01.14</b>	<b>43</b>	2,00 4,41	0,004 0,14	1 1
	160 63"	2,5 1"	8 3 1/4"	<b>703.ZB.01.16</b>	<b>47</b>	2,30 5,07	0,005 0,17	1 1
	200 78 3/4"	2,5 1"	8 3 1/4"	<b>703.ZB.01.20</b>	<b>67</b>	2,50 5,50	0,006 0,21	1 1
 <p><b>zoccolo metallico per modulo bancone 90° raccordo / terminale (optional)</b></p> <p>base metal frame for reception unit 90° 2-ways / terminal (optional)</p> <p>zócalo metálico para módulo mostrador 90° 1 via / 2 vias (opcional)</p> <p>socle métallique pour module comptoir 90° raccord 1 ou 2 voies (option)</p> <p>Metallsockel für gerade Rezeption 90° (Optional)</p> <p>rodapé metálico para módulo balcão 90° terminal / interligação (opcional)</p>	84 33 1/8"	84 33 1/8"	8 3 1/4"	<b>703.ZB.02.08</b>	<b>58</b>	2,00 4,41	0,003 0,10	1 1

V02 colonna column	W	H
--------------------------	---	---

COMPONENTI PER BANCONE COMPONENTS FOR RECEPTION	L. W.	P. D.	H. H.	CODICE CODE	V04	Kg. lb	m <sup>3</sup> ft <sup>3</sup>	n. no.
 <p><b>gamba dritta intermedia in metallo</b></p> <p>straight metal middle leg</p> <p>pata recta intermedia de metal</p> <p>piétement droit intermédiaire en métal</p> <p>gerade Zwischentischbein aus Metall</p> <p>perna recta intermediária em metal</p>	5 2"	5 2"	71,5 28 1/4"	<b>703.GM.01.01</b>	<b>45</b>	3,00 6,61	0,016 0,56	1 1

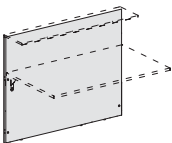

pannelli verticali vertical panels	WN	GQ	RC	NM	RS	RT
---------------------------------------	----	----	----	----	----	----

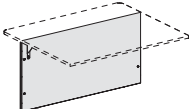
COMPONENTI PER BANCONE COMPONENTS FOR RECEPTION	L. W.	P. D.	H. H.	CODICE CODE	PREZZO PRICE	Kg. lb	m <sup>3</sup> ft <sup>3</sup>	n. no.
	80 31 1/2"	2,5 1"	110 43 3/8"	<b>703.SQ.01.08</b>	<b>185</b>	17,90 39,46	0,044 1,55	2 2
	140 55 1/8"	2,5 1"	110 43 3/8"	<b>703.SQ.01.14</b>	<b>251</b>	30,70 67,69	0,072 2,54	2 2
	160 63"	2,5 1"	110 43 3/8"	<b>703.SQ.01.16</b>	<b>265</b>	34,50 76,07	0,081 2,86	2 2
	Non disponibile - RS / NM Not available - RS / NM	200 78 3/4"	2,5 1"	110 43 3/8"	<b>703.SQ.01.20</b>	<b>421</b>	42,50 93,71	0,090 3,18
<b>schiena per modulo bancone</b> back panel for straight reception unit trasera para módulo mostrador recto dos pour module comptoir droit Rückwandblende für gerade Rezeption costas para módulo balcão								
	84 33 1/8"	84 33 1/8"	110 43 3/8"	<b>703.SQ.02.08</b>	<b>364</b>	39,10 86,21	0,073 2,57	2 2
<b>schiena per modulo bancone angolo 90°</b> back panel for 90° reception unit trasera para módulo mostrador 90° dos pour module comptoir 90° Rückwandblende für gerade Rezeption 90° costas para módulo balcão 90°								
	140 55 1/8"	2,5 1"	71,5 28 1/4"	<b>703.SQ.03.14</b>	<b>161</b>	21,10 46,52	0,048 1,69	2 2
<b>schiena per modulo bancone con piano conversazione L.140 cm</b> back panel for straight reception unit L.140 cm with conversation top trasera para módulo mostrador recto L. 140 cm y tablero de conferencia dos pour module comptoir droit L. 140 cm accueil Rückwandblende für gerade Rezeption L. 140 cm für Gesprächsplatte costas para módulo balcão L.140 cm com mesa de atendimento								

piani worktops	WN	GQ	RC	NM	RS	RT
-------------------	----	----	----	----	----	----

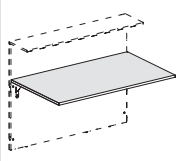
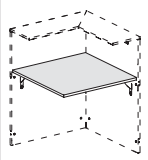
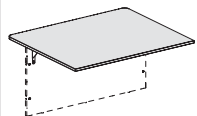
COMPONENTI PER BANCONE COMPONENTS FOR RECEPTION	L. W.	P. D.	H. H.	CODICE CODE	PREZZO PRICE	Kg. lb	m <sup>3</sup> ft <sup>3</sup>	n. no.
 <p><b>piano scrivania per modulo bancone</b></p> <p>working top for straight reception unit</p> <p>mesa para módulo mostrador</p> <p>plateau pour module comptoir</p> <p>Schreibtischplatte für gerade Rezeption</p> <p>plano de escrivaninha para módulo balcão</p>	80 31 1/2"	80 31 1/2"	2,5 1"	<b>703.PQ.01.08</b>	<b>92</b>	12,00 26,46	0,031 1,09	1 1
	140 55 1/8"	80 31 1/2"	2,5 1"	<b>703.PQ.01.14</b>	<b>124</b>	20,60 45,42	0,053 1,87	1 1
	160 63"	80 31 1/2"	2,5 1"	<b>703.PQ.01.16</b>	<b>139</b>	22,20 48,95	0,060 2,12	1 1
	200 78 3/4"	80 31 1/2"	2,5 1"	<b>703.PQ.01.20</b>	<b>162</b>	29,00 63,94	0,074 2,61	1 1
 <p><b>piano scrivania per modulo bancone 90°</b></p> <p>working top for straight reception unit 90°</p> <p>mesa para módulo mostrador 90°</p> <p>plateau pour module comptoir 90°</p> <p>Schreibtischplatte für gerade Rezeption 90°</p> <p>plano de escrivaninha para módulo balcão 90°</p>	80 31 1/2"	80 31 1/2"	2,5 1"	<b>703.PQ.02.08</b>	<b>92</b>	12,00 26,46	0,031 1,09	1 1
 <p><b>piano scrivania per modulo bancone con piano conversazione L.140 cm</b></p> <p>working top for straight reception unit L.140 cm with conversation top</p> <p>mesa para módulo mostrador L.140 cm con tablero de conferencia</p> <p>plateau pour module comptoir L.140 cm avec plateau accueil h.72</p> <p>Schreibtischplatte für gerade Rezeption L. 140 cm mit Gesprächsplatte</p> <p>plano de escrivaninha para módulo balcão L.140 cm com tampo de atendimento</p>	140 55 1/8"	115 45 3/8"	2,5 1"	<b>703.PQ.03.14</b>	<b>213</b>	30,20 66,59	0,063 2,22	1 1

# DV703 Qubo

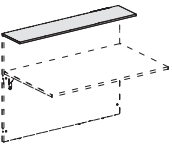
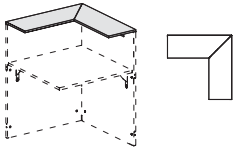

COMPONENTI PER BANCONC COMPONENTS FOR RECEPTION	L. W.	P. D.	H. H.	CODICE CODE	V01		Kg. lb	m <sup>3</sup> ft <sup>3</sup>	n. no.
					M1	L			
 <p><b>top per modulo bancone</b> top for straight reception unit encimeras para módulo mostrador recto top pour module comptoir droit Abdeckplatte für gerade Rezeption tampos para módulo balcão</p>	80 31 1/2"	28 11 1/8"	1,8 3/4"	<b>703.TQ.01.08</b>	<b>51</b>	<b>101</b>	3,50 7,71	0,010 0,35	1 1
	140 55 1/8"	28 11 1/8"	1,8 3/4"	<b>703.TQ.01.14</b>	<b>67</b>	<b>138</b>	6,50 14,33	0,017 0,60	1 1
	160 63"	28 11 1/8"	1,8 3/4"	<b>703.TQ.01.16</b>	<b>72</b>	<b>145</b>	7,50 16,53	0,019 0,67	1 1
	200 78 3/4"	28 11 1/8"	1,8 3/4"	<b>703.TQ.01.20</b>	<b>110</b>	<b>153</b>	7,80 17,19	0,024 0,84	1 1
 <p><b>top per modulo bancone 90° 2 vie</b> top for reception unit 90° 2-ways encimeras para módulo mostrador 90° elemento de unión 2 vías top pour module comptoir 90° 2 voies Abdeckplatte für gerade Rezeption 90° 2-weg tampos para módulo balcão 90° 2 vias</p>	! 84 33 1/8"	84 33 1/8"	1,8 3/4"	<b>703.TQ.02.08</b>	<b>111</b>	<b>247</b>	6,10 13,45	0,016 0,56	1 1

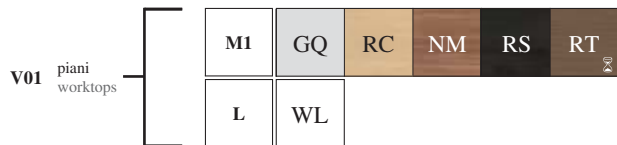

V81 Verso Hand	Sx	Dx
----------------	----	----

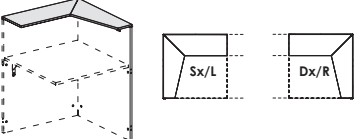
COMPONENTI PER BANCONC COMPONENTS FOR RECEPTION	L. W.	P. D.	H. H.	CODICE CODE	V01		Kg. lb	m <sup>3</sup> ft <sup>3</sup>	n. no.	
					M1	L				
 <p><b>top terminale sinistro/destro per modulo bancone 90°</b> left / right terminal top for reception unit 90° encimeras terminal izquierdo / derecho para módulo mostrador 90° top d'extrémité gauche / droit pour module comptoir 90° Abdeckplatte für gerade Rezeption 90°, link / rechts tampos terminal esquerda / direita para módulo balcão 90°</p>	Sx. / Dx. L. / R.	84 33 1/8"	84 33 1/8"	1,8 3/4"	<b>703.TQ.03.08</b>	<b>129</b>	<b>258</b>	7,40 16,31	0,018 0,63	2 2

# DV703 Qubo

V01 top accettazione decorative top	M1	WN	GQ	RC	NM	TD	RS	RT
	M2	NO						

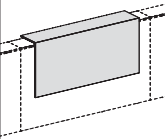
COMPONENTI PER BANCONE COMPONENTS FOR RECEPTION	L. W.	P. D.	H. H.	CODICE CODE	V01		Kg. lb	m <sup>3</sup> ft <sup>3</sup>	n. no.
					M1	M2			
	140 55 1/4"	32,3 12 3/4"	74 29 1/4"	703.TA.01.14	424	481	31,00 68,35	0,071 2,50	2 2
	160 63"	32,3 12 3/4"	74 29 1/4"	703.TA.01.16	452	509	34,00 74,97	0,081 2,86	2 2
<p><b>Top accettazione</b></p> <p>Decorative top</p> <p>Encimera decorativa</p> <p>Top décoratif</p> <p>Empfangstheke Aufsatzplatte</p> <p>Tampo atendimento</p>									

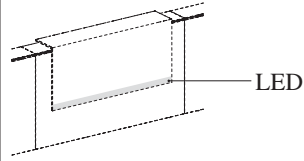
COMPONENTI PER BANCONE COMPONENTS FOR RECEPTION	CODICE CODE	PREZZO PRICE	Kg. lb	m <sup>3</sup> ft <sup>3</sup>	n. no.
	703.LQ.02.14	244	1,80 3,96	0,004 0,14	1 1
	703.LQ.02.16	256	2,30 5,07	0,006 0,21	1 1
<p><b>Barra led (optional) per top accettazione - alimentatore incluso</b></p> <p>LED spotlight (optional) for decorative top - electrical feeder included</p> <p>Barra de iluminación led (opcional) para encimera decorativa - alimentador incluido</p> <p>Spot LED (en option) pour top décoratif - ballast inclus</p> <p>LED Beleuchtung (Option) für Empfangstheke Aufsatzplatte - einschließlich Netzteil</p> <p>Barra de Led (opcional) para Tampo atendimento - alimentador incluido</p>					

V04 box box	WN	HH
-------------	----	----

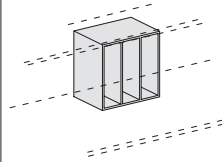
ACCESSORI ACCESSORIES	L. W.	P. D.	H. H.	CODICE CODE	V04	Kg. lb	m <sup>3</sup> ft <sup>3</sup>	n. no.
	35 13 7/8"	24 9 1/2"	35 13 7/8"	300.AC.14.03	112	4,50 9,92	0,031 1,09	1 1
	<p><b>box multiuso</b></p> <p>multipurpose box</p> <p>box multiuso</p> <p>box multifonction</p> <p>Mehrzweck-Schrank</p> <p>box multi-uso</p>							

# DV703 Qubo

**N.B. Ad ogni alimentatore con rispettivo interruttore, si possono collegare in linea max. 6 barre led Art. 703.LQ.03.00.**

**In composizione fare attenzione che la lunghezza dei cavi delle barre led in dotazione sia sufficiente per arrivare all'alimentatore**

N.B.: to each feeder with switch you can connect max. 6 led light rails Code 703.LQ.03.00 in line. When composing, please make sure that the supplied LED bars cable length is sufficient to reach the power supply

N.B.: A cada alimentador con su interruptor, se pueden conectar en línea max 6 barras LED Art. 703.LQ.03.00. Atención que la longitud de los cables de las barras LED sea suficiente para alcanzar la fuente de alimentación

N.B.: à chaque alimentateur avec son interrupteur, on peu brancher maximum 6 barres LED Art. 703.LQ.03.00 en ligne. En composant, faire attention que la longueur des câbles des barres LED fournis soit suffisante pour atteindre l'alimentation

N.B.: An jedem Vorschaltgerät mit Schalter kann man in eine Linie bis max. 6 LED-Lichtleisten Art. 703.LQ.03.00 anschließen. Bei der Planung bitte darauf achten, dass die Kabellänge der mitgelieferten LED-Schienen ausreicht, um die Stromversorgung zu erreichen

N.B.: A cada alimentador com respectivo interruptor, podem ser ligadas em linha no max. 6 fitas de led Art. 703.LQ.03.00. Em composições ter atenção para que o comprimento dos cabos pelo LED sejam suficientes para alcançar a fonte de alimentação

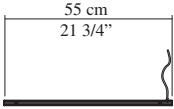
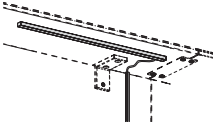
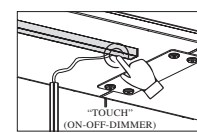
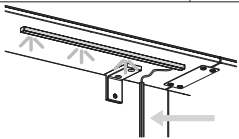
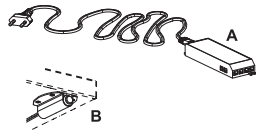
ACCESSORI ACCESSORIES	L. W.	P. D.	H. H.	CODICE CODE	PREZZO PRICE	Kg. lb	m <sup>3</sup> ft <sup>3</sup>	n. no.
 	55 21 3/4"			<b>703.LQ.03.00</b>	<b>128</b>	0,60 1,32	0,001 0,03	1 1
	 <p><b>Pulsante di accensione luci led (posizionato solo su un lato)</b> Power button led lights (placed only on one side) Botón de encendido luces led (posicionado solo sobre un lado) Bouton d'alimentation lumières led (positionné seulement sur un coté) Einschalte-Taste fuer LED Lampe (nur ein einer Stirnseite) Interruptor de luz LED (posicionado apenas de um lado)</p>							
<b>Barra led sottotop (Optional)</b>  Under-top LED spotlight (Optional)  Barra de iluminación led bajotop (Opcional)  Spot LED sous-top (En option)  LED Beleuchtung (Option)  Barra de Led sob o tampo (Opcional)	 <p><b>Lunghezza cavo barra led per collegamento con alimentatore = mt 1,9 - 74 7/8"</b> Cable length LED light rail for connection with feeder = mt 1,9 - 74 7/8" Cable barra led para conexión alimentador = mt 1,9 - 74 7/8" de largo Longueur câble de la barre LED pour branchement avec alimentateur = mt 1,9 - 74 7/8" LED-Lichtleiste Kabellänge für Anschluss an Vorschaltgerät = 1,9 LM - 74 7/8" Comprimento do cabo da fita LED para ligação com alimentador = mt 1,9 - 74 7/8"</p>							
 <p><b>Kit Alimentatore/trasformatore (A) di potenza 15 W/100-240 V a 24 V con interruttore per alimentatore</b> Electrical feeder/transformer (A) 15W/100-240 V power, 24 V with switch for feeder including a free Kit Alimentador/trasformador (A) de potencia 15 W/100-240 V a 24 V con interruptor para alimentador c Jeu alimentateur/transformateur (A) puissance 15W/100-240 V à 24 V avec interrupteur pour alimentate Vorschaltgerät/Transformator (A) Leistung 15W / 100-240 V bei 24 V mit Schalter für Vorschaltgerät, Kit com alimentador/transformador (A) de potência 15 W/100-240 V a 24 V com interruptor para o alime</p>				<b>703.KQ.03.00</b>	<b>95</b>	0,40 0,88	0,001 0,03	1 1

COMPOSIZIONE IN GRES GRES COMPOSITION	L. W.	P. D.	H. H.	CODICE CODE	PREZZO PRICE	Kg. lb	m <sup>3</sup> ft <sup>3</sup>	n. no.
 <p><b>Composizione in gres</b> Gres composition Compostion en grès Composición en gres Komposition in Steinzeug Composição de grés</p>	247 97 1/4"	84 33 1,4"	112,5 44 1/4"	<b>703.CM.P1</b>	<b>15.803</b>	365,75 804,65	0,341 12,05	10 10
	<p><b>Finiture - finishes - acabados - finitions- farben - acabamentos</b></p> <div style="display: flex; justify-content: space-around;"> <div style="text-align: center;">  <p><b>VGB</b> Bianco "Extra White" White "Extra White" Blanco "Extra White" Blanc "Extra White" Weiß "Extra White" Branco "Extra White"</p> </div> <div style="text-align: center;">  <p><b>VGN</b> Nero "Marquina" Black "Marquina" Negro "Marquina" Noir "Marquina" Schwarz "Marquina" Preto "Marquina"</p> </div> </div> 							

DV701  
ABAKO  
LED

DV703  
QUBO

## CANALIZZAZIONE PER MODULI BANCONE

Wire management for counter modules / Canalización para módulos mostradores / Electrification pour modules banque / Kabelführung für Empfangstischmodule / Canalização para módulos balcão

Canale passacavi in lamiera piegata / Wire management of sheet metal / Canal pasacables en chapa doblada / Goulotte passe-câbles en acier plié / Kabelführungskanäle aus gebogenem Blech / Canal passa-cabos com chapa de aço dobrada

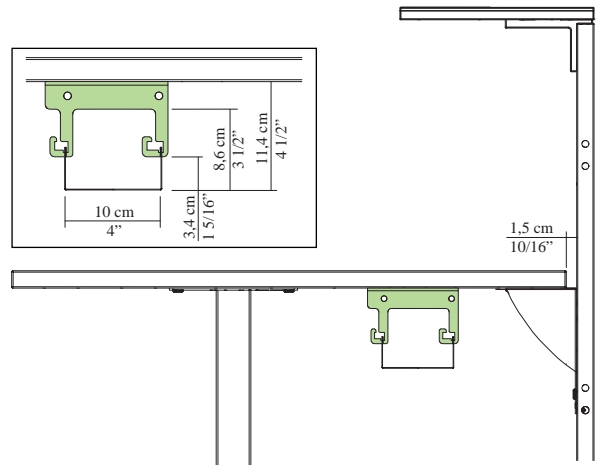
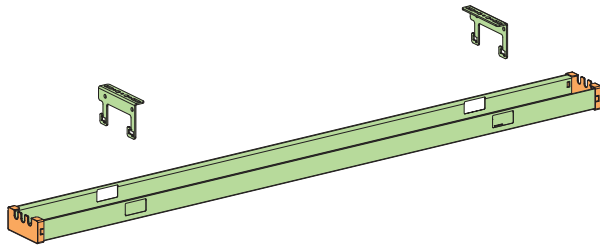

Cod. 703.MB.01.08

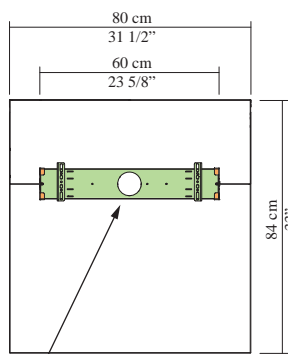

Cod. 300.AP.25.06

Cod. 703.MB.01.14

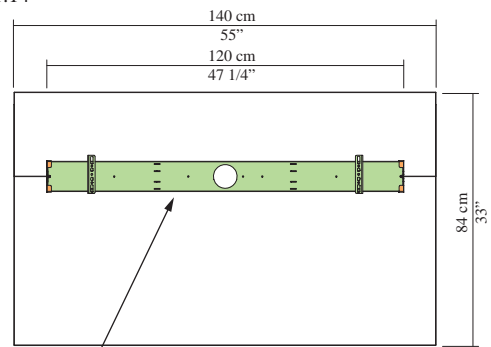

Cod. 300.AP.25.12

Cod. 703.MB.01.16

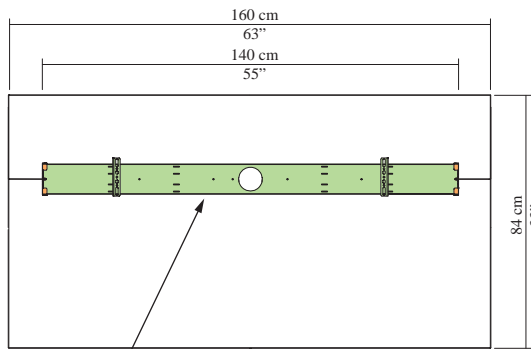

Cod. 300.AP.25.14

Cod. 703.MB.01.20

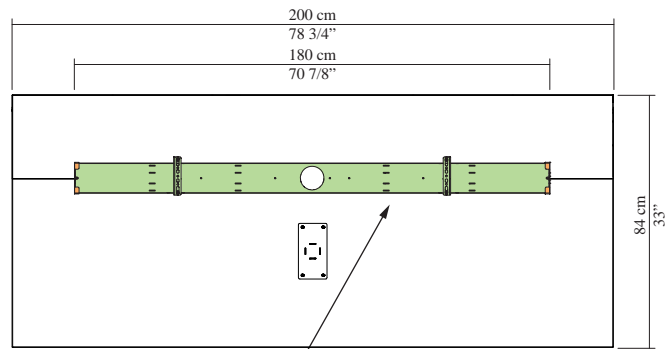

Cod. 300.AP.25.18

Cod. 703.MB.02.14

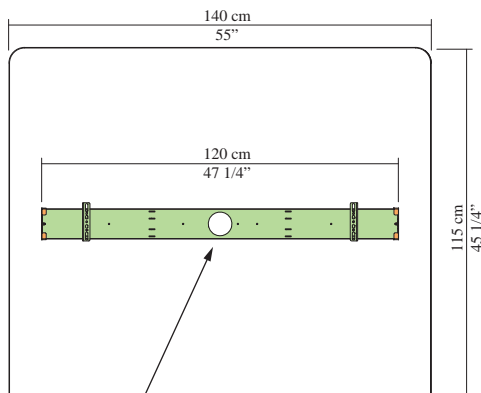

Cod. 300.AP.25.12

Cod. 703.MB.03.08

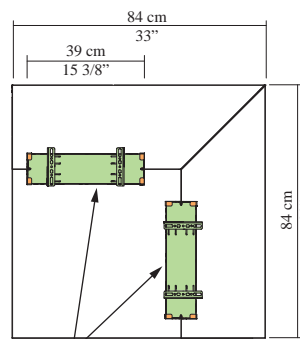

Cod. 703.AP.25.04

Cod. 703.MB.04.08

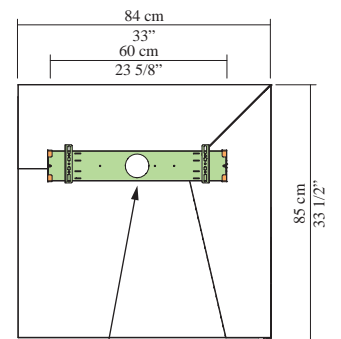

Cod. 300.AP.25.06

# DV703 Qubo

## vedi note tecniche

see technical notes  
ver manual técnico  
voir notes techniques  
siehe Technikanmerkungen  
ver notas técnicas

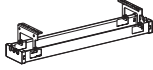
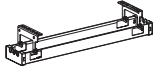
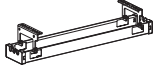
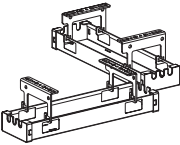
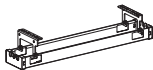
CANALIZZAZIONE WIRE MANAGEMENT		L. W.	P. D.	H. H.	CODICE CODE	PREZZO PRICE	Kg. lb	m <sup>3</sup> ft <sup>3</sup>	n. no.
 <p><b>canale passacavi per Art. 703.MB.01.08 / 703.MB.04.08</b></p> <p>wiring management for 703.MB.01.08 / 703.MB.04.08</p> <p>canal para el paso de los cables para art.703.MB.01.08 / 703.MB.04.08</p> <p>goulotte pour art. 703.MB.01.08 / 703.MB.04.08</p> <p>Kabelkanal für Art. 703.MB.01.08 / 703.MB.04.08</p> <p>canalização para art. 703.MB.01.08 / 703.MB.04.08</p>	60 23 5/8"	10,2 4 1/8"	11,4 4 1/2"	<b>300.AP.25.06</b>	<b>48</b>	0,90 1,98	0,003 0,10	1 1	
 <p><b>canale passacavi per Art. 703.MB.01.14 / 703.MB.02.14</b></p> <p>wiring management for 703.MB.01.14 / 703.MB.02.14</p> <p>canal para el paso de los cables para art. 703.MB.01.14 / 703.MB.02.14</p> <p>goulotte pour art. 703.MB.01.14 / 703.MB.02.14</p> <p>Kabelkanal für Art. 703.MB.01.14 / 703.MB.02.14</p> <p>canalização para art. 703.MB.01.14 / 703.MB.02.14</p>	120 47 1/4"	10,2 4 1/8"	11,4 4 1/2"	<b>300.AP.25.12</b>	<b>57</b>	2,00 4,41	0,007 0,24	1 1	
 <p><b>canale passacavi per Art. 703.MB.01.16</b></p> <p>wiring management for 703.MB.01.16</p> <p>canal para el paso de los cables para art. 703.MB.01.16</p> <p>goulotte pour art. 703.MB.01.16</p> <p>Kabelkanal für Art. 703.MB.01.16</p> <p>canalização para art. 703.MB.01.16</p>	140 55 1/8"	10,2 4 1/8"	11,4 4 1/2"	<b>300.AP.25.14</b>	<b>61</b>	2,20 4,85	0,009 0,31	1 1	
 <p><b>coppia canali passacavi per Art. 703.MB.03.08</b></p> <p>double wiring management for 703.MB.03.08</p> <p>couple canal para el paso de los cables para art.703.MB.03.08</p> <p>goulotte pour art. 703.MB.03.08</p> <p>Kabelkanal für Art. 703.MB.03.08</p> <p>canalização casal para art. 703.MB.03.08</p>	45 17 3/4"	10,2 4 1/8"	11,4 4 1/2"	<b>703.AP.25.04</b>	<b>84</b>	1,60 3,52	0,004 0,14	2 2	
 <p><b>canale passacavi per Art. 703.MB.01.20</b></p> <p>wiring management for 703.MB.01.20</p> <p>canal para el paso de los cables para art. 703.MB.01.20</p> <p>goulotte pour art. 703.MB.01.20</p> <p>Kabelkanal für Art. 703.MB.01.20</p> <p>canalização para art. 703.MB.01.20</p>	180 70 7/8"	10,2 4 1/8"	11,4 4 1/2"	<b>300.AP.25.18</b>	<b>67</b>	2,80 6,17	0,012 0,42	1 1	

DV702  
LED

DV701  
ABAKO

DV703  
QUBO

